

APP

High head impeller



All product images are indicative only

General characteristics

High head impeller	
motor power	7,2 ÷ 10 kW
poles	2
discharge	GAS 2"- DN32 horizontal
free passage	10 mm
max flow rate	11.8 l/s
max head	58.3 m

Electromechanical assembly

Electromechanical assembly in GJL-250 cast iron, for submerged operation. Seal set comprising 2 (two) silicon carbide mechanical seals installed in series in inspectable oil sump and 1 (one) opposed graphite-alumina lip seal lubricated by the motor oil. Oil bath motor.

Applications

Used for clear and sandy wastewater, rainwater and seepage. The considerable manometric head guarantees excellent results for the creation of water features and decorative fountains; suitable for use in agriculture, irrigation and the fish processing sector.

Construction materials

Case	Cast iron EN-GJL 250
Impeller	Cast iron EN-GJL-250
Nuts and bolts	Stainless steel - Class A2-70
Standard gasket	Rubber - NBR
Shaft	Stainless steel - AISI 420
Cooling jacket	Carbon steel or stainless steel AISI 304
Paint type	Ecological bicomponent epoxy (medium thickness 150 µm)
Set of standard mechanical seals	Two silicon carbide mechanical seals (2SiC) and one carbon-aluminium oxide mechanical seal (AL)

Operating limits

Maximum operating temperature	40 °C
PH of treated fluid	6 ÷ 14
Viscosity of treated fluid	1 mm ² /s
Maximum immersion depth	20 m
Density of treated fluid	1 Kg/dm ³
Maximum acoustic pressure	70 dB
max starts per hour	20

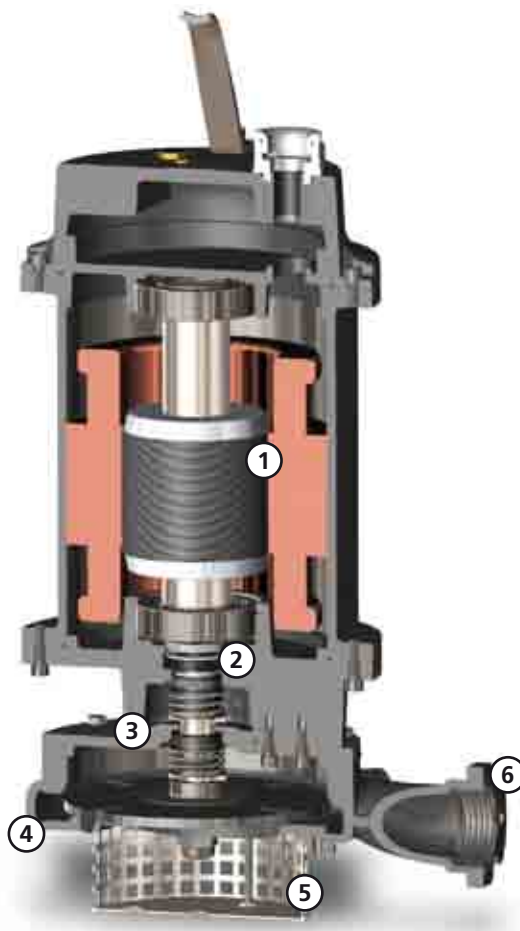

1 Motor
Oil-bath motor with thermal protections.



2 Mechanical seals
Two mechanical seals in silicon carbide (2SiC) and one mechanical seal in alumina graphite (AL) for maximum reliability even in heavy-duty applications.



3 Oil sump
Large oil sump to guarantee longer mechanical seal lifetime.



4 Anti-clogging system
The special design of the hydraulic part ensures the expulsion of suspended solids and prevents fouling of the impeller.



5 Intake strainer
Intake strainer in stainless steel.



6 Discharge
Threaded, flanged discharge for the maximum ease of installation.

APP

Models with horizontal GAS 2" threaded - DN32 PN6 flanged discharge - 2 poles

Performances

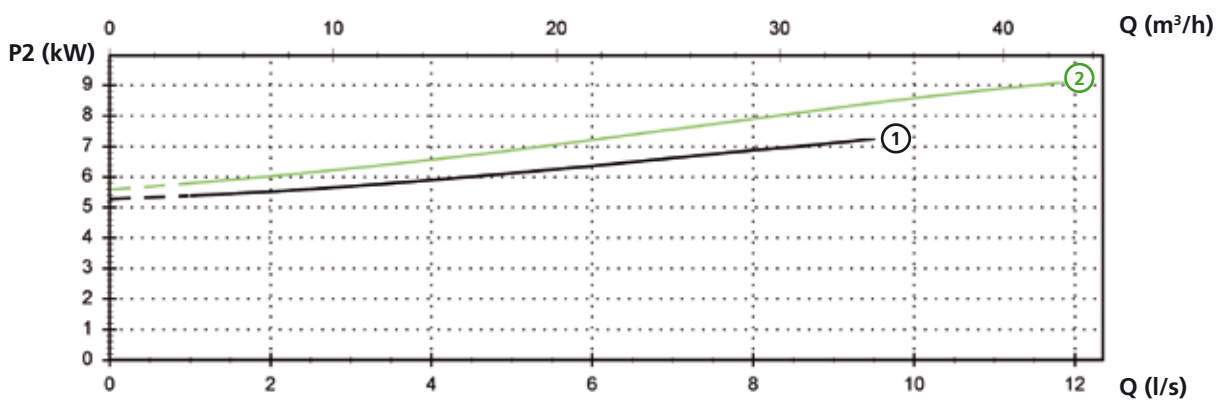
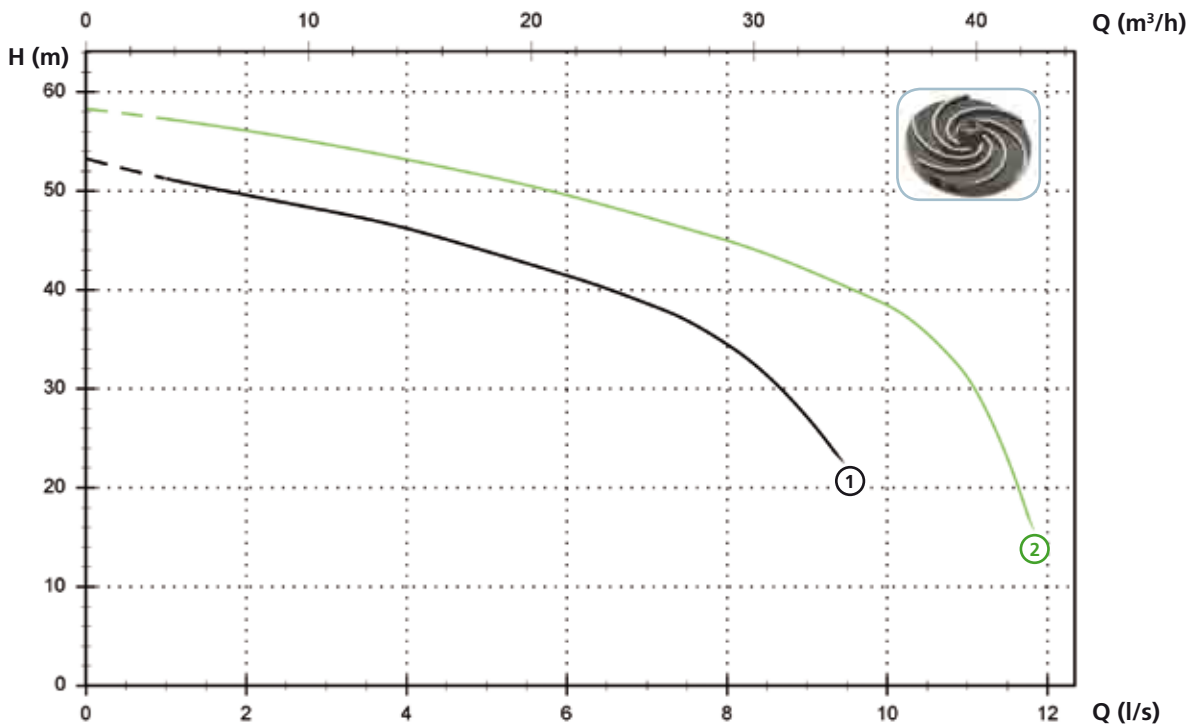

Technical data

	V	Phases	P1 (kW)	P2 (kW)	A	Rpm	Start	Ø	Free passage
① APP 750/2/G50H A0HT/50	400	3	8.8	7.2	14.5	2900	Y Δ	G 2" - DN32 PN6	10 mm
② APP 1000/2/G50H A1HT/50	400	3	12.4	10	19.8	2900	Y Δ	G 2" - DN32 PN6	10 mm

Versions available

(Key to versions on page 16)

	Electrical variants											Cooling				Mechanical seals				
	N A E	T	T C	T C D	T C D T	T C D G T	T C G	T C S T	T C S G T	T S	T R	T R G	N	CC CCE	FT	C G F T	2SIC	SICM	SICAL	2SICAL
APP 750/2/G50H A0HT/50		●								●			●							●
APP 1000/2/G50H A1HT/50		●								●			●							●

Overall dimensions and weights

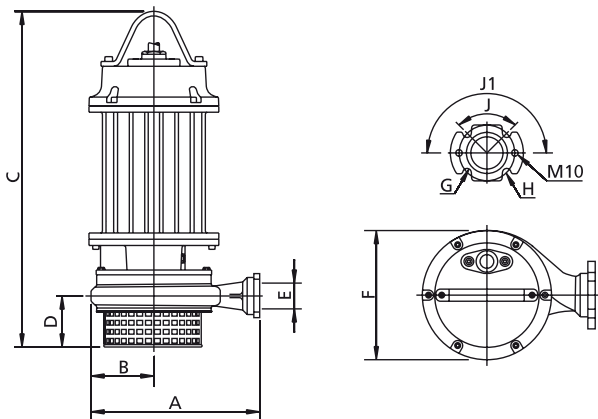

	A	B	C	D	E	F	G	H	J	J1	kg
APP 750/2/G50H A0HT/50	355	135	650	45	G 2"	270	14	90	90°	180°	90
APP 1000/2/G50H A1HT/50	355	135	650	45	G 2"	270	14	90	90°	180°	96

Dimensions in mm

All weights and dimensions are indicative only

Packaging dimension

	A	B	C
APP 750/2/G50H A0HT/50	725	445	415
APP 1000/2/G50H A1HT/50	725	445	415

Dimension in mm

All weights and dimensions are indicative only

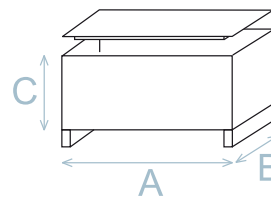

Installations available

